

SEQUOIA LIGHTING

C O R P O R A T I O N
 13644 George Blvd, Suite 1 (760) 246-5213
 Victorville, CA, 92394 Fax: (760) 246-5294

MANUFACTURERS OF QUALITY ROADWAY PRODUCTS

CAST ALUMINUM SOFFIT HOUSING

FEATURES:

- Meets the California Department of Transportation requirements for Soffit Luminaire Housing.
- Heavy sealed die cast aluminum housing designed for the harshest outdoor roadway applications.
- The Soffit Housing is coated with a heavy bitumastic finish for protection against any corrosive concrete and roadway elements.
- Each Soffit Housing is provided with (4) 2" threaded hubs for easy conduit access.
- Fully machined, the Soffit Housing is provided with (5) five brass screws for securing the ballast kit and Alzak® reflector for any future applications.
- Also available are the brass swing door assemblies with a heavy duty 1/4" thick steel plate for future applications.



SOFFIT LUMINAIRE HOUSING
 *CALTRANS APPROVED

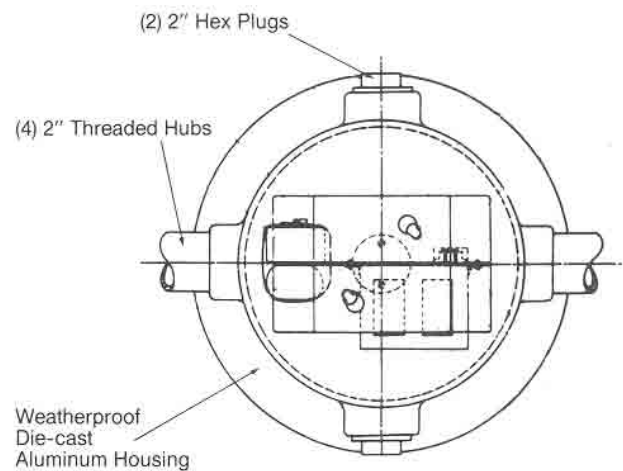

TOP VIEW

ORDERING INFORMATION

CATALOG NO.	DESCRIPTION	TYPE
2000SFT-A-H	SOFFIT HOUSING	ALUMINUM
2000SFT-S-P	STEEL PLATE (FUTURE APPLICATIONS)	STEEL

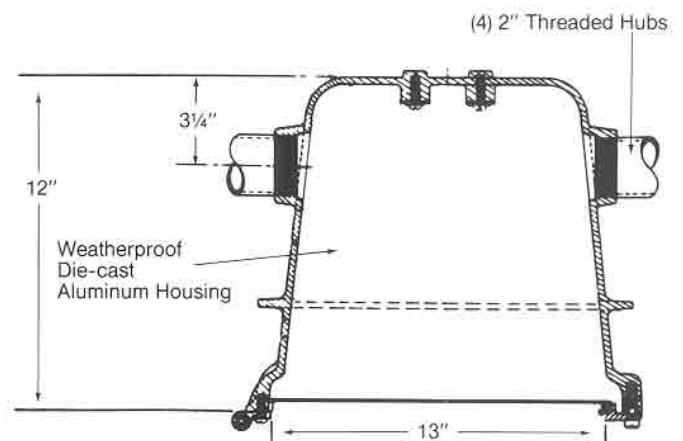

SIDE VIEW

This document contains proprietary information of the Sequoia Lighting Corp. and is transmitted in confidence. Any reproduction, disclosure, or use of this document is expressly prohibited except as Sequoia Lighting Corp. may otherwise agree in writing.

COPYRIGHT 1993 © SEQUOIA LIGHTING CORPORATION.