

PTB-2

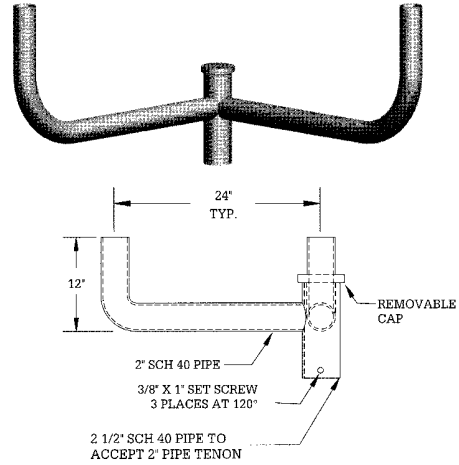

PTB-2A

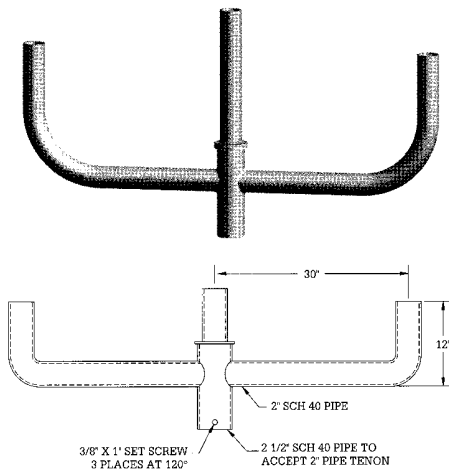

PTB-3

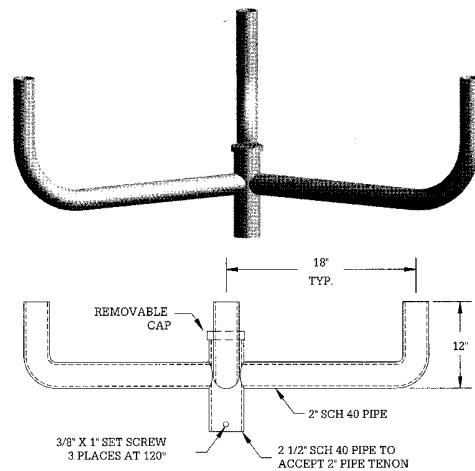

PTB-3A

SPECIFICATIONS

All Sequoia Lighting post top mount arm assemblies slip fit over a variety of pole tops. Each has a maximum capacity of one to four luminaires depending on mounting configuration. Brackets come complete with locking set are finished to match pole. Brackets cataloged are fabricated from steel and are designed for use on steel or aluminum poles

FINISH

All post top arm assemblies are cleaned, etched and primed prior to painting. Standard colors for cross arms are black, green and verde patina powder coated or wet sprayed. Custom colors and special finishes along with hot dip galvanizing are also available.

*If required post top arm is not shown please consult factory.

SEQUOIA LIGHTING
CORPORATION

MANUFACTURERS OF QUALITY LIGHTING PRODUCTS

13644 George Blvd, Suite 1, Victorville, CA, 92394 (760) 246-5213 FAX (760) 246-5294 www.sequoialighting.com